

- 1 HOUSING: POLYESTER, GRAY. UL 94V-0. CONTACT: PHOSPHOR BRONZE.
- 2 CONTACT: MATING AREA: 1.27µm MIN GOLD OR 0.08µm MIN GOLD OVER 0.76µm MIN PALLADIUM-NICKEL. ACTION PIN AREA: 0.5µm MIN TIN PLATE. ALL OVER 1.27µm MIN NICKEL UNDERPLATE.
- 3 CONTACT LUBRICATION WITH BELCORE APPROVED LUBRICANT. TECHNICAL REFERENCE: TR-NWT-001217 ISSUE 1, SEPT 1992.
- 4 REFERENCE APPLICATION SPEC 114-1103 FOR RECOMMENDED PLATED THRU HOLE DIAMETER AND PLATING THICKNESS.
- 5 NUMBER "2" MARKED IN THIS AREA.
- 6 HOUSING: POLYESTER, GRAY. UL 94V-0. CONTACT: HI-CURRENT COPPER ALLOY.
- 7 CURRENT RATING 10A/CONTACT FOR PHOS BRONZE CONTACT AND 16A/CONTACT FOR HIGH CURRENT COPPER ALLOY CONTACTS PER PRODUCT SPEC 108-1651.

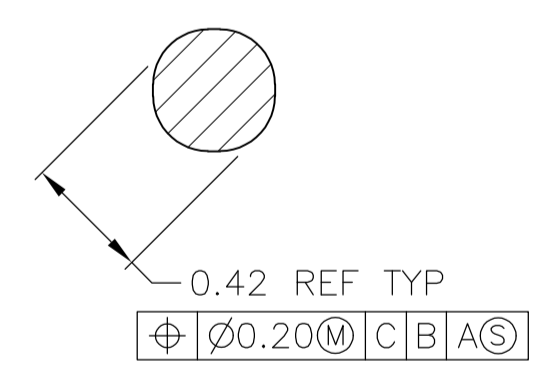

SECTION W-W  
SCALE 40:1

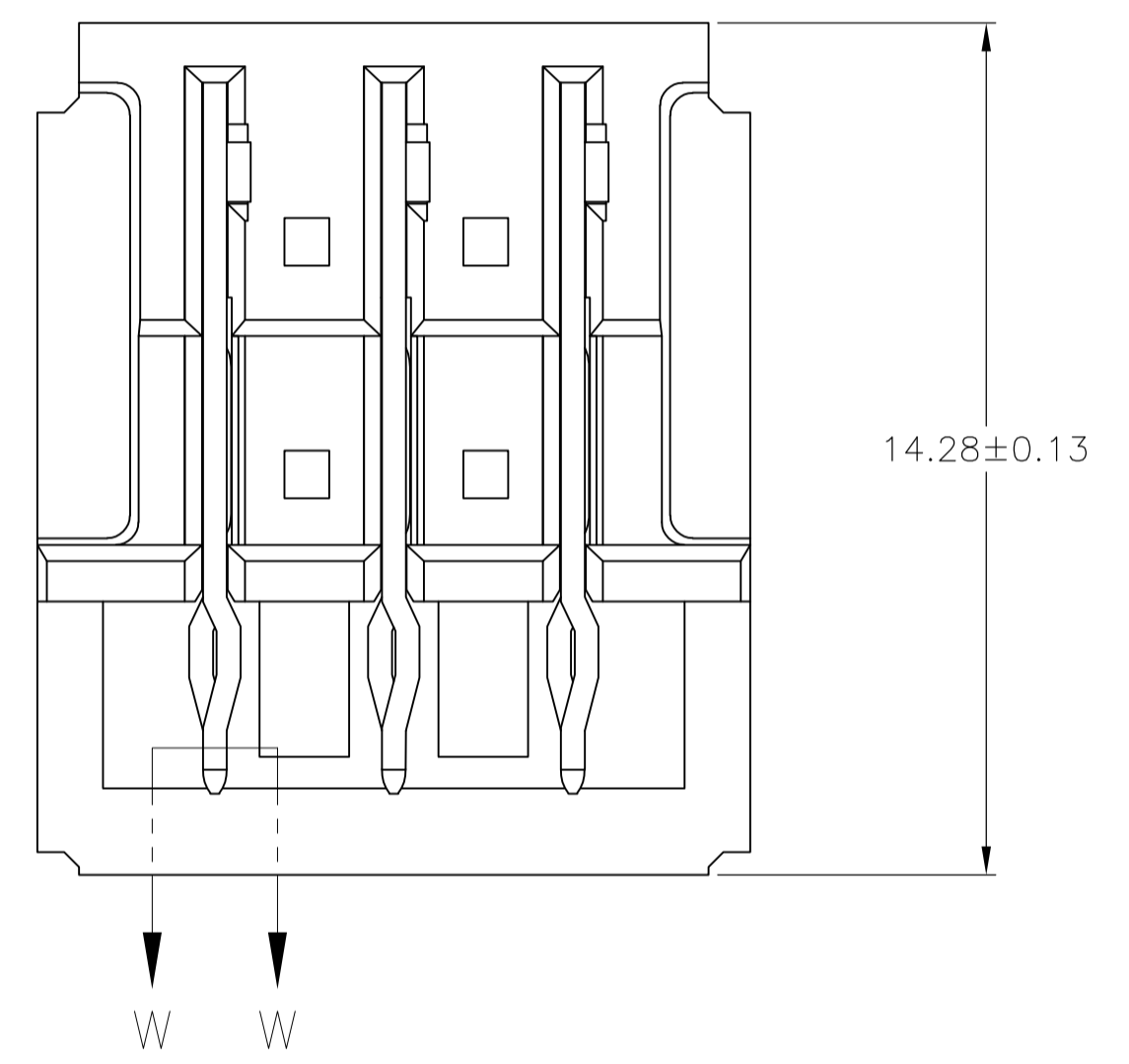
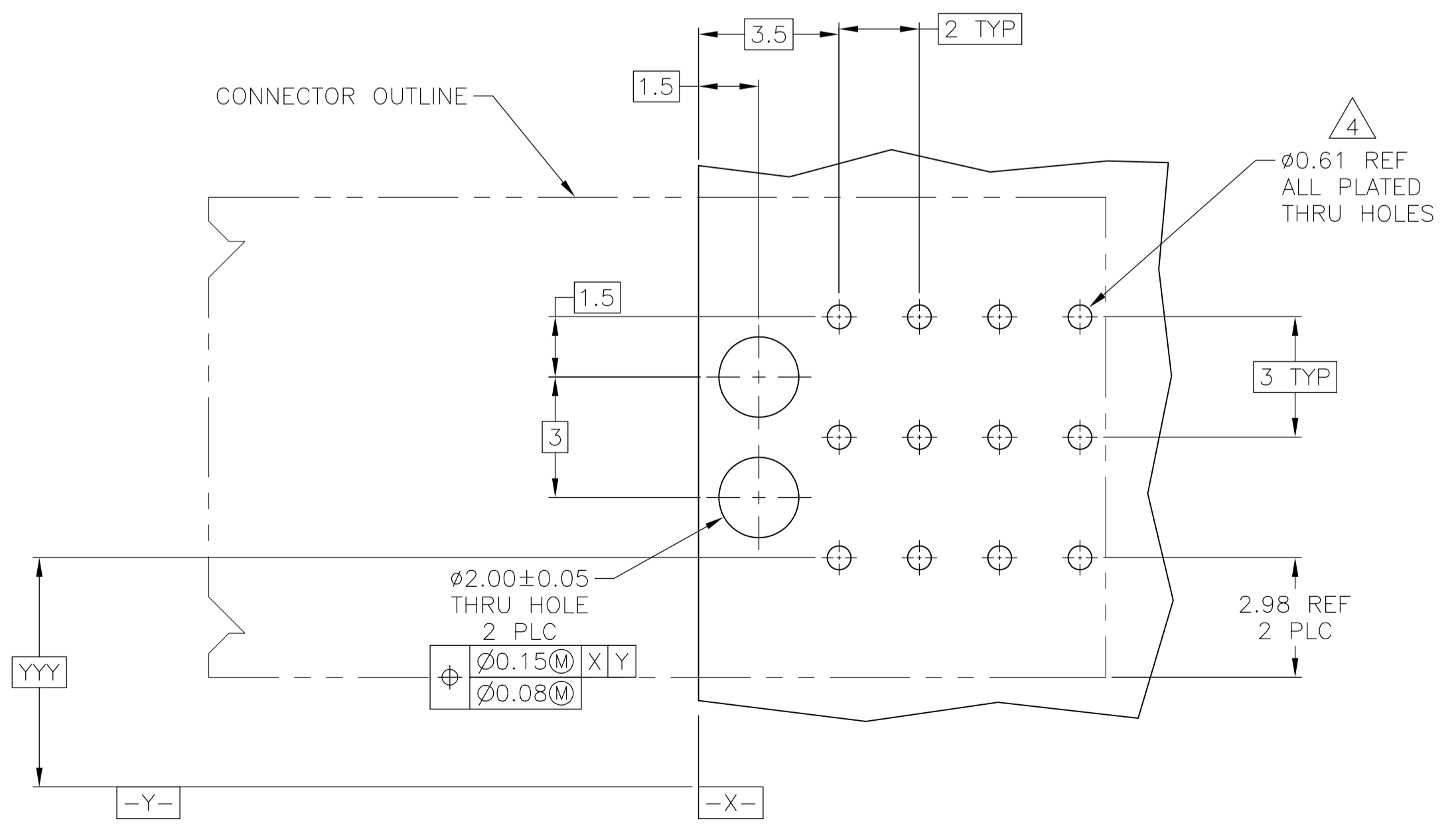

RECOMMENDED PCB HOLE LAYOUT

|         |   |   |   |             |
|---------|---|---|---|-------------|
| 5       | 2 | 3 | 6 | 5-5223963-1 |
| 1       | 2 | 3 |   | 5223963-7   |
| 1       | 2 | 3 |   | 5223963-1   |
| REMARKS |   |   |   | PART NUMBER |

|  |  |                  |              |   |      |  |
|--|--|------------------|--------------|---|------|--|
| THIS DRAWING IS A CONTROLLED DOCUMENT. |  | DIN              | B. CARBO     | 29OCT04   |      |  |
| DIMENSIONS: mm                         |  | CHK              | R. PATTERSON | 29OCT04   |      |  |
| TOLERANCES UNLESS OTHERWISE SPECIFIED: |  | APVD             | R. PATTERSON | 29OCT04   | NAME |  |
| 0 PLC ± -                              |  | PRODUCT SPEC     |              | ASSEMBLY, RIGHT ANGLE HEADER, W/ RETENTION PEGS, UNIVERSAL POWER MODULE |      |  |
| 1 PLC ± -                              |  | APPLICATION SPEC |              | SIZE  |      |  |
| 2 PLC ± 0.13                           |  |                  |              | CAGE CODE   |      |  |
| 3 PLC ± -                              |  |                  |              | DRAWING NO  |      |  |
| 4 PLC ± -                              |  |                  |              | RESTRICTED TO   |      |  |
| ANGLES ± -                             |  |                  |              | WEIGHT  |      |  |
| FINISH                                 |  | SEE TABLE        |              | SCALE   |      |  |
| MATERIAL                               |  | SEE TABLE        |              | SHEET   |      |  |
|  |  |                  |              | 1 OF 1  |      |  |
|  |  |                  |              | REV   |      |  |
|  |  |                  |              | C   |      |  |